

## AE-1220 Spiral Mixer 40 Qt Bowl, 44 Lbs of Dough

American Eagle spiral mixers meet every baker's challenge: high-capacity, high-efficiency machines at an affordable price. Their exceptional reliability make it ideal for busy cooks by decreasing mixing times and maintenance. This versatile mixer makes a variety of dough from bagels to pizza.

The machine of choice for busy chefs

- Shorter mixing times
- Higher output
- Consistent results

### Spiral Mixing Technology: The Secret to Better dough

Why do European artisan breads taste better? The most important thing besides your recipe is the way dough is handled. Used for decades in European-style bakeries, spiral mixers can imitate hand-kneading and rolling motions. The gentle coordinated movement of bowl and agitator controls blending while preventing overdeveloped dough. The dough stays cooler, mixes in less time, and has better consistency.

### Features

- Heavy-duty agitator is 25% thicker than industry leader
- Handles heavier pizza & bagel dough with ease
- Reversible mixing action makes better dough, and in less time
- Heavy-duty construction and powerful two-motor system
- Easy maintenance and time-saving versatility
- Heat treated enamel coating resists scratches, rust, and dents
- Mounted on castors for extra mobility and easy maintenance
- Overload relay protects motor and transmission
- Approvals: NSF No. 8, ETL, CE, CSA

### Standard Accessories

- Stainless steel extra durable spiral agitator
- Stainless steel stationary bowl w/ 40Qt Bowl
- Stainless steel safety guard
  - Locking mechanism prevents operation when lifted
  - See through to bowl guard
- Two 60 min timers automatically shift between high and low speed

### Standard Warranty

- 1 year parts and ninety days labor
- Bagel and pizza dough rated at low speeds only  
Use in high speed voids warranty
- Must register with American Eagle

### Other Available Sizes:

- AE-3050 80 Qt Spiral Mixer
- AE-4060 100 Qt Spiral Mixer
- AE-5080 120 Qt Spiral Mixer
- Special Order: AE-75K & AE-100K Spiral Mixers



American Eagle: Value, Quality, and Reliability

Contact an American Eagle representative today to find the right sized mixer for your operation!



**FOOD MACHINERY, INC.**

3557 S. Halsted St, Chicago, Illinois 60609  
800-836-5756 ▪ sales@ameagle.biz

# AE-1220 Spiral Mixer

## 40 Qt Bowl, 44 Lbs of Dough

### Specifications

*Due to continuous product improvement, specifications may change without notice*

<p><b><u>Agitator (Arm) Specifications</u></b></p> <p><b>Spiral Arm Motor:</b> 1.5 HP (4 Amps) Overload protection w/ reset button.</p> <p><b>Arm Agitator Speeds:</b> Low-148 rpm, High-284 rpm Manual (continuous) mixing</p> <p><b>Transmission:</b> Belt-drive transmission made from specially patented, resilient fibers.</p> <p><b><u>Bowl Specifications</u></b></p> <p><b>Capacity:</b> 42 Quarts (40 Liters) 100% high polish stainless steel stationary bowl.</p> <p><b>Motor:</b> 1/3 HP (7 Amps). Moves the bowl in coordinated fashion to arm.</p> <p><b>Bowl Guard</b> See-through stainless steel guard stands up to the toughest challenges. Interlocking mechanism prevents mixing until guard is fully closed</p>	<p><b><u>Other Specifications</u></b></p> <p><b>Quality Materials:</b> High polish stainless steel meets food industry sanitation needs. Sturdy cast iron-frame. Non-porous food surfaces easily wipe off after use.</p> <p><b>Voltages:</b> 220V /60 Hz / 3Ph Permissible voltage range: 198 Volts to 242 Volts (+/- 10%)</p> <p><b>Cord:</b> 6 ft. flexible four wire cord. Electrical connections must be made by qualified personnel in accordance with applicable codes and regulations.</p> <p><b>Speed Mode:</b> The machine must be turned off before shifting speed mode. Push red stop button, select High or Low Speed to turn on again.</p> <p><b>Timer:</b> Each speed is automatically controlled by an accurate sixty minute digital timer, ensuring consistency. Machine can also operate with timer disabled.</p>	<p><b><u>Shipping Information:</u></b></p> <p><b>Shipping Weight:</b> Freight Class: 85 Net Weight: 330 lbs. (150 kgs.) Shipping Weight: 390 lbs.(177 kgs.)</p> <p>Crates are affixed to a skid (pallet). The weight of this skid is included above and may vary from shipment to shipment.</p> <p><b>Shipping Dimensions:</b> 23"W x 35"D x 50"H (58cm x 89cm x 127cm)</p> <p><b>Dimensions:</b> Foot Print = 26.4" x 13.4" (41.7cm x 38.0 cm) Overall Width = 18.9" (48 cm) Overall Depth = 29.1" (74 cm) Overall Height = 45.3" (115 cm)</p>
--	--	---

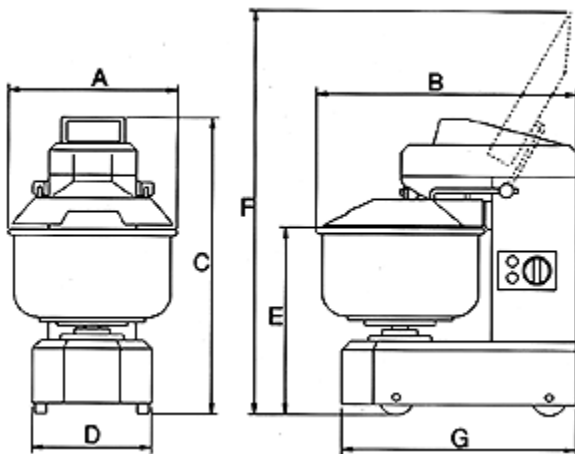

Dimensions		
A	18.9 in	48 cm
B	29.1	74
C	33.5	85
D	13.4	34
E	20.9	53
F	45.3	115
G	26.4	67

### Specifications Summary

Bread Dough Capacity (Lbs)  
Flour                      Dough  
26 Lbs                      44 Lbs

Bagel Dough Capacity  
Flour                      Dough  
20 Lbs                      32 Lbs